

NTSC



## Video Analyzer R&S UAF

### Perfection in video analysis

- ◆ Ease of operation
- ◆ 3 signal inputs
- ◆ 25 video parameters
- ◆ Limit monitoring
- ◆ Full-field measurements
- ◆ Convenient result display
- ◆ Freely selectable test signal
- ◆ Memory card
- ◆ Printer interface
- ◆ Remote control (IEC/IEEE bus)
- ◆ Small dimensions
- ◆ High-speed measurements



**ROHDE & SCHWARZ**



Measurement accuracy for satisfying studio quality requirements and measuring times in the seconds range – these are the standards which have to be met in present-day automatic video measurement engineering. By virtue of its outstanding characteristics, the Video Analyzer R&S UAF fully complies with these requirements. User-friendly operation and a clear display with graphics support ensure straightforward measurements. Moreover, the R&S UAF is of state-of-the-art and lightweight design featuring great flexibility and compactness.

### Characteristics and use

The signal analysis comprises 25 video and test line parameters and covers all important levels as well as linear and nonlinear distortions such as 2T K rating, frequency response and hum. The position of the test lines can be freely selected over the entire picture area and in the field blanking interval; storage of up to eight test configurations is possible.

Owing to its variable integration time, the R&S UAF can be adapted to all test conditions. Using the shortest integration time of less than 1 s, the R&S UAF is ideal for all alignments, be it in the studio or in production.

In the case of very noisy VTR signals, on long transmission links or at the end of a long line of transposers, increasing the integration time to 2.5 s, 5 s or 10 s always yields stable results.

For measurements in the field, on cable networks or at inaccessible points in transmitters, it is not necessary to bring along a computer or printer to log data. Using a plug-in memory card, customer-defined test and data-logging programs can be loaded and the test results also stored on the card.

Moreover, the memory card permits storage of complete instrument setups: limit values, test parameter definitions, filter settings in the case of noise voltage measurements as well as line numbers of the eight test configurations. Thus any measurement can be reproduced.

For use in quality and production control of video recorders, the R&S UAF also handles the Y/C component signals.

Distorted test signals due to jitter or head switchover for instance do not affect the operation of the R&S UAF.

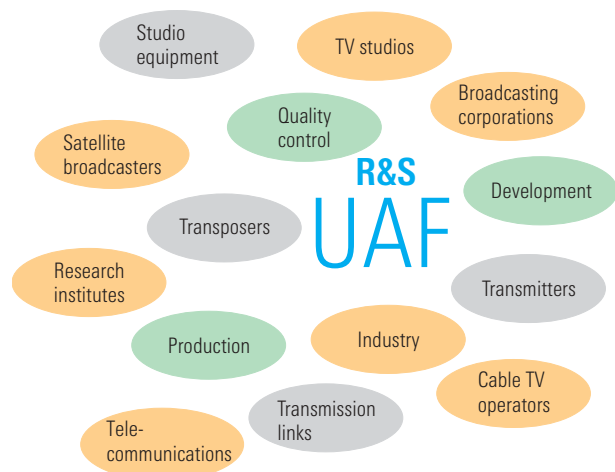

*A selection of the manifold applications of the R&S UAF*

## Operation

The logical arrangement of the R&S UAF front-panel controls offers a clear overview of its functions and ensures ease of operation.

Each parameter is assigned its own key. The associated LED above the key blinks if the limit values are exceeded. Thus all parameters can be checked at a glance for adherence to set limits.

The illuminated LC display shows the result in large figures which are easy to read even from some distance. Several parameters can be displayed at the same time in small characters. For certain applications, e.g. alignment, the bar indication proves useful.

The complete device setup and the selected limit values are contained in the upper lines of the display. The lower part shows the function of the unlabelled keys. These softkeys offer user prompting with respect to the displayed measured value or the called function.

The small keypad to the left of the display permits the setup menus of the R&S UAF to be selected directly. Such a menu is inserted as a window above the normal result display. It is possible to use the softkeys for changing general settings such as selected input, synchronization or printer mode.

Further test parameters, e.g. an external level or future extensions, can be called up using the "option" function.

For integration into computer-controlled test systems, all functions of the R&S UAF can be remote-controlled via an IEC/IEEE-bus interface. The R&S UAF can also be used as the controller. If parameter logging is required for acceptance test measurements, a printer can be connected directly to the Centronics interface.

Mode 1	Mode 2	Mode 3	Mode 4	Mode 5	Mode 6	Mode 7	Mode 8
<b>Test signal</b> e.g. NTC7 or FCC				<b>Parameter definitions</b> e.g. S/N, weighting filter on/off			
<b>Test line</b> e.g. NTC7 composite in line 14							
<b>Limit values</b> e.g. BAR Set 1: 95 IRE/105 IRE Set 2: 90 IRE/110 IRE Hysteresis: 2 IRE							

*For rapid recall, for instance within a test routine, the R&S UAF is able to store up to 8 test configurations (modes 1 to 8)*

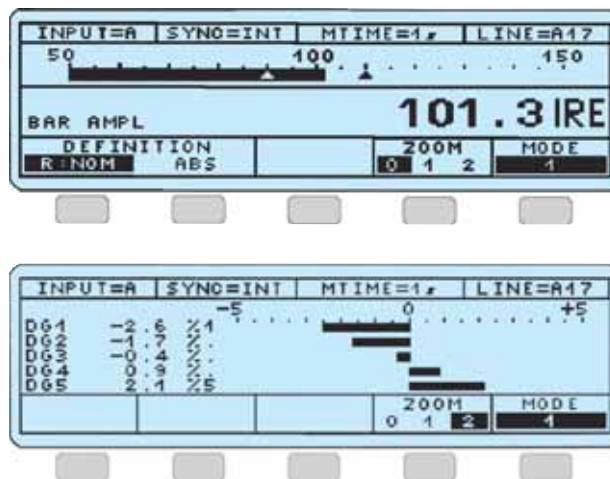

*The test results are displayed in the form of numerical values or bars*

## Special modes

### Difference measurement

This mode permits signal errors at the input of the device under test (DUT) to be eliminated. For this purpose the input signal of the DUT is applied to channel A and the output signal to channel B of the R&S UAF. In this way it is possible to perform measurements on a transposer system or a cable headend receiving incorrect input signals.

Because of the high display accuracy of the R&S UAF, the difference measurement mode is also suitable for high-precision studio measurements on components such as routing switchers which feature stringent tolerances.

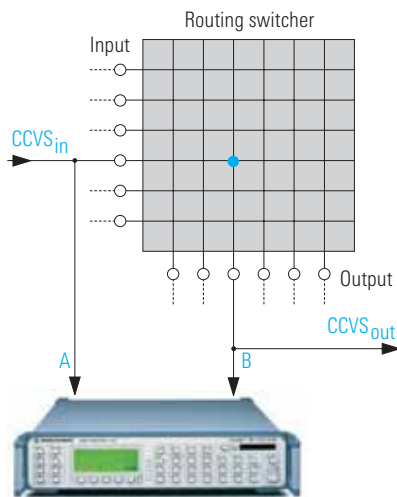

**Difference measurement**

### Reference measurement

In this mode, only one input of the R&S UAF is connected to the DUT, the first test cycle being stored as the reference. This mode facilitates determination of the effect of the environment (EMC, climate, etc) on video generators in the lab and in servicing.

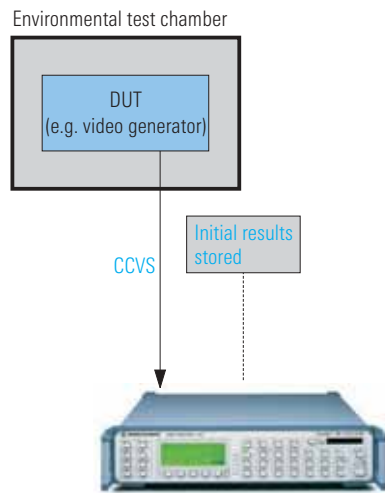

**Reference measurement**

### Automatic test sequence

The AUTORUN menu allows test sequences to be programmed on the R&S UAF front panel; these sequences are executed automatically and can be repeated cyclically using the built-in realtime clock. An AUTORUN routine may for instance ensure input switchover, mode variation, limit monitoring and result logging.

Since the R&S UAF is able to act as a controller for other IEC/IEEE-bus instruments, its controller functions can be included in an AUTORUN routine. Thus it is for instance possible to send commands to an IEC/IEEE-bus-compatible TV test receiver in order to set the receive channel. Without the use of a controller, the R&S UAF is able to set all channels of a cable network, monitor the signal quality and print error logs in the AUTORUN mode.

## Description and technology

The combination of analog signal conditioning and digital result processing is the basis of the powerful performance of the R&S UAF in spite of its small size.

In the analog section, the video signal is processed in parallel by different precision test circuits for chrominance and luminance measurements. An A/D converter digitizes both the test circuit output voltages and parts of the video signal directly. Its 12-bit resolution together with the precise analog circuitry ensure the unique measurement accuracy of the R&S UAF.

The core of the digital section is a micro-processor plus an arithmetic coprocessor. It rapidly calculates the results from the samples averaging them over the integration time. The computing power is such that all test parameters are constantly calculated, updated and monitored without leaving out any samples. In addition, the keypads, interfaces and the memory card are serviced.

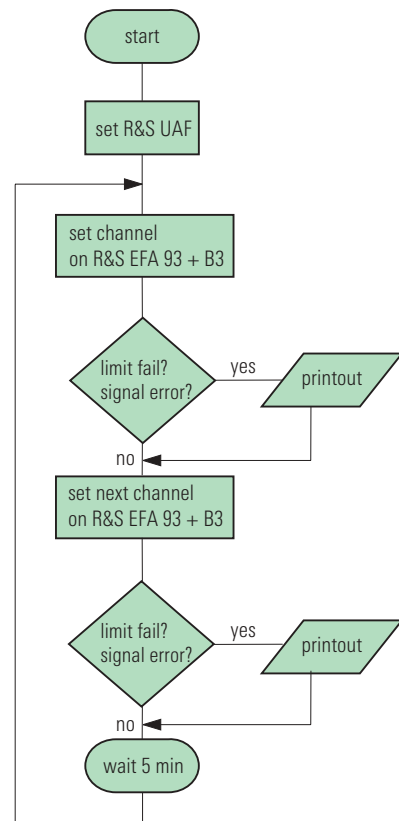

**Example of AUTORUN routine**



Rear panel of R&S UAF

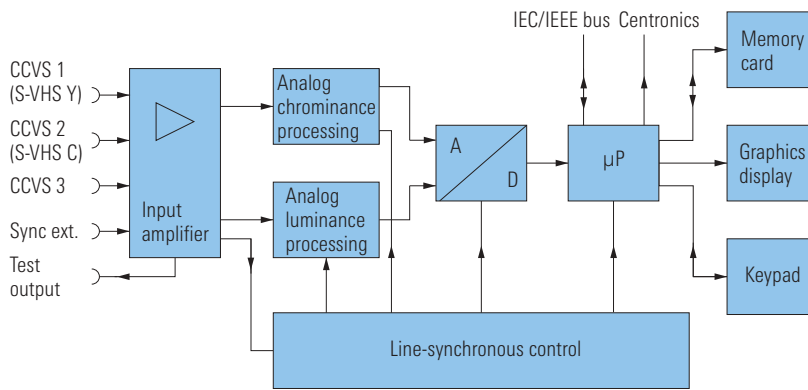















Block diagram of R&S UAF

Certified Quality System  
**ISO 9001**  
DQS REG. NO 1954

Certified Environmental System  
**ISO 14001**  
REG. NO 1954

## Specifications

Test parameter		Key label	Measurement range	Resolution	Error limits <sup>1)</sup> at nominal	Additional max. error per 1% (1°, 1 ns) departure from nominal
Luminance bar amplitude		BAR AMPL	0 IRE to 200 IRE	0.1 IRE	±0.3 IRE	0.015 IRE
Black level distortion		BASELINE DIST	-20 IRE to +40 IRE	0.1 IRE	±0.3 IRE	0.045 IRE
Tilt of luminance bar		TILT	-40 IRE to +40 IRE	0.1 IRE	±0.3 IRE	0.045 IRE
2T pulse amplitude		2T AMPL	-50 IRE to +50 IRE	0.1 IRE	±0.5 IRE	0.03 IRE
2T K factor		2T K FACTOR	0% to +10%	0.1%	±0.7%	0.03%
Luminance nonlinearity		LUM NL	0% to +50%	0.1%	±0.5%	0.01%
Residual picture carrier		RES PC	0% to +30%	0.1%	±0.3%	0.015%
Demodulator blanking level		RES PC	50% to 90%	0.1%	±0.3%	0.015%

Test parameter		Key label	Measurement range	Resolution	Error limits <sup>1)</sup> at nominal	Additional max. error per 1% (1°, 1 ns) departure from nominal
Sync pulse amplitude Reference = signal Reference = nominal		SYNC AMPL	20 IRE to 60 IRE 8 IRE to 80 IRE	0.1 IRE 0.1 IRE	±0.2 IRE ±0.2 IRE	0.04 IRE 0.04 IRE
Chrominance/luminance gain inequality		C/L GAIN	50IRE to 150 IRE	0.1 IRE	±1.0 IRE	0.02 IRE
Chrominance/luminance intermodulation		C/L INTERMOD	-50% to +50%	0.1	±0.3%	0.01%
Chrominance / luminance delay inequality		C/L DELAY	-500 ns to +500 ns	1 ns	±5 ns	0.01 ns
Differential gain positive/negative peak-to-peak		DIFF GAIN	-50% to +50% 0% to +100%	0.1% / 0.01% <sup>2)</sup> 0.1% / 0.01% <sup>2)</sup>	±0.3% ±0.5%	0.025% 0.015%
Differential phase positive/negative peak-to-peak		DIFF PHASE	-50° to +50° 0° to +100°	0.1° / 0.01° <sup>2)</sup> 0.1° / 0.01° <sup>2)</sup>	±0.3° ±0.5°	0.025° 0.015°
Nonlinearity of colour subcarrier gain positive/negative peak-to-peak		C NL GAIN	-50% to +50% 0% to +100%	0.1% 0.1%	±0.7% ±1.0%	0.025% 0.02%
Nonlinearity of colour subcarrier phase positive/negative peak-to-peak		C NL PHASE	-50° to +50° 0° to +100°	0.1° 0.1°	±0.7° ±1.0°	0.025° 0.02°
Burst amplitude Reference = signal Reference = nominal		BURST AMPL	-50 IRE to +50 IRE -80 IRE to +80 IRE	0.1 IRE 0.1 IRE	±0.4 IRE ±0.4 IRE	0.008 IRE 0.008 IRE
Multiburst amplitude		MULTIB 1 to 6	10 IRE to 75 IRE	0.1 IRE	±0.5 IRE	0.01 IRE
Signal/noise ratio		S/N	25 dB to 80 dB	0.1 dB	±1 dB	—
Intermodulation between colour subcarrier and sound carrier		C/SND INTERMOD	30 dB to 70 dB	0.1 dB	±1 dB	—
Hum		HUM	6 dB to 60 dB	0.1 dB	±1 dB	—
DC measurement			-5 V to +5 V	5 mV	±10 mV	—

<sup>1)</sup> With difference and reference measurement modes, attainable error limits are ±2 digits for all parameters.

<sup>2)</sup> Higher resolution for difference and reference measurements.

<b>Signal inputs</b>	3 video inputs, 75 $\Omega$ loopthrough filters, 3 x CCVS or 1 x Y/C and 1 x CCVS, adjustable
Level	1 V ( $V_{pp}$ ) $\pm$ 6 dB
Return loss up to 10 MHz	$\geq$ 40 dB
Decoupling of inputs up to 10 MHz	$\geq$ 85 dB
<b>Synchronization</b>	
Internal	optionally from one of the three inputs, sync pulse level 40 IRE $\pm$ 6 dB
External	1 input, loopthrough filter, nominal level 2 V/4 V into 75 $\Omega$ ( $V_{pp}$ )
<b>Parameters</b>	25 test parameters, direct key selection
Noise voltage Measurement mode Filter	rms 200 kHz highpass and video filter integrated, weighting filter and colour subcarrier trap can be connected
Inherent S/N ratio Reference	$>$ 83 dB luminance bar or 714 mV nominal, selectable
Test signals	NTC7, FCC, NE-TV
<b>Special functions</b>	
SETUP	setting of test signal, test lines, ON state, display mode, limit values, IEC/IEEE-bus address, printer type, date and time
MEAS TIME	measuring time 1/2.5/5/10 s, selectable
MEAS HOLD	measured values of all parameters are simultaneously frozen
PRINT	measured value output via printer (Centronics interface)
MONITORING	limit monitoring of single parameters, parameter groups or all parameters; two upper and two lower parameter limits freely adjustable for every mode
Limit monitoring	out-of-limit indication by blinking of associated LED, acoustic alarm can be switched on, error logging
AUTORUN	entry and recall of user-defined test routine
Difference measurement	selectable between two inputs (measuring time doubled)
Reference measurement	one test cycle stored as reference

<b>Indication</b>	LC display, display mode selectable numerical, 1 parameter numerical, 3 parameters numerical with bar display
Types of indication	measured value, limit values, major modes, prompting
<b>Interfaces and outputs</b>	
IEC/IEEE bus	interface to IEC 625-2/IEEE 488-2
Printer	Centronics interface
Memory card	storage of measured values, limit values and parameter definitions, device setups and user-defined test routines
Monitor output	clamped test signal, also for display of measurement timing, level same as input signal $\pm$ 1%, 75 $\Omega$
Zero reference control	2.5 V ( $V_{pp}$ ) $\pm$ 10% into 75 $\Omega$ , position and duration adjustable

### General data

Rated temperature range	+5 °C to +45 °C (application class I to IEC 359)
Power supply	100/120/220/240 V $\pm$ 10%, 47 Hz to 63 Hz, 115 VA, safety class 1
Dimensions (W x H x D)	435 mm x 103 mm x 460 mm
Weight	10 kg

### Ordering information

Video Analyzer Standard M (please inquire for different standards)	R&S UAF	2028.5774.02
<b>Accessories supplied</b>		
Power cord Spare fuses Manual Four 75 $\Omega$ Terminations RMF 2 Memory card 32 Kbyte		
<b>Recommended extras</b>		
Memory Card 32 Kbyte	R&S ZZM-32	2005.4394.02
Memory Card 512 Kbyte	R&S ZZ11-512	2005.4388.02
Service manual		





**ROHDE & SCHWARZ**

ROHDE&SCHWARZ GmbH & Co. KG · Mühlendorfstraße 15 · 81671 München · Germany · P.O.B. 80 14 69 · 81614 München · Germany · Telephone +49 89 4129-0  
www.rohde-schwarz.com · Customer Support: Telephone +49 1805124242, Fax +49 89 4129-13777, E-mail: CustomerSupport@rohde-schwarz.com